

## **WARNING**

**THIS PRODUCT USES POWERFUL LEDs. DIRECT VIEWING OF THE LED LIGHT/S AT CLOSE RANGE SHOULD BE AVOIDED.**

**KEEP PRODUCT AWAY FROM CHILDREN.**

**HAVING ISSUED THIS WARNING LITEWAVE LTD ACCEPTS NO RESPONSIBILITY FOR ISSUES ARISING FROM ANY FAILURE TO COMPLY WITH THIS CLEAR INSTRUCTION.**

**LITEWAVE LTD WILL NOT ACCEPT RESPONSIBILITY FOR ANY OTHER ISSUES ARISING FROM IMPROPER USE OR FITTING OF THIS PRODUCT AS THESE MATTERS ARE BEYOND OUR CONTROL.**

## **Installation**

Prior to Installation we advise that you bench test the RGB Spotlight, it is usually tested prior to dispatch. Connect the black wire to the positive (+) wire of the power supply (a 9v pp3 will also work), then separately connect the 3 remaining wires to the negative (-) wire of the power supply (or battery) to confirm that each of the primary colours – Red, Green, and Blue are all working.

Ensure that all of the LEDs are fully lit – **AVOID VIEWING THE LEDS DIRECTLY**

## **Wiring**

There are 4 wires from the RGB Spotlight, they can be extended if necessary by using any 4-Core cable rated at the appropriate amperes depending on how many Spotlights you are connecting. For example a 3A cable will have capacity for 10 RGB Spotlights.

**Wiring without the ICELED Flexidriver.** The best way for basic control (although you will only get 7 colours) is to use a switch along each of the wires except for the black wire which connects to the positive. The switch in turn should be connected to the negative of the power supply.

However we would advise using our Flexidriver which will give you a colour range of 2.1 million colours by varying the power to each of the 3 colours. For even further control use the Flexidriver in conjunction with a ZAP+ or ZEN Controller.

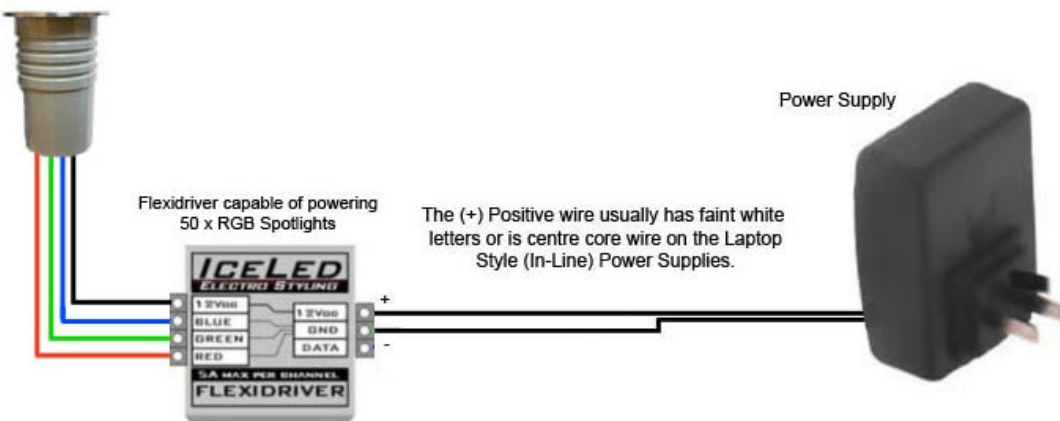

**Wiring the RGB Spotlight to the Flexidriver** Connect the black wire to the terminal labeled "12VDC", the remaining coloured wires should be connected to the corresponding labels on the Flexidriver as shown, make sure all the screws are tightened securely onto the wires – being careful not to trap the insulation under the screw as this could cause a poor connection. Next you will need to connect the 12vdc power supply to the Flexidriver.

The positive (+) wire from the output of the Power Supply should be connected to the "12VDC" label on the Flexidriver, the remaining wire connects to the "GND" label. Switch on the power to the power supply, the RGB Spotlight should now light up if it does not immediately switch off power and re-check all fuses and connections.

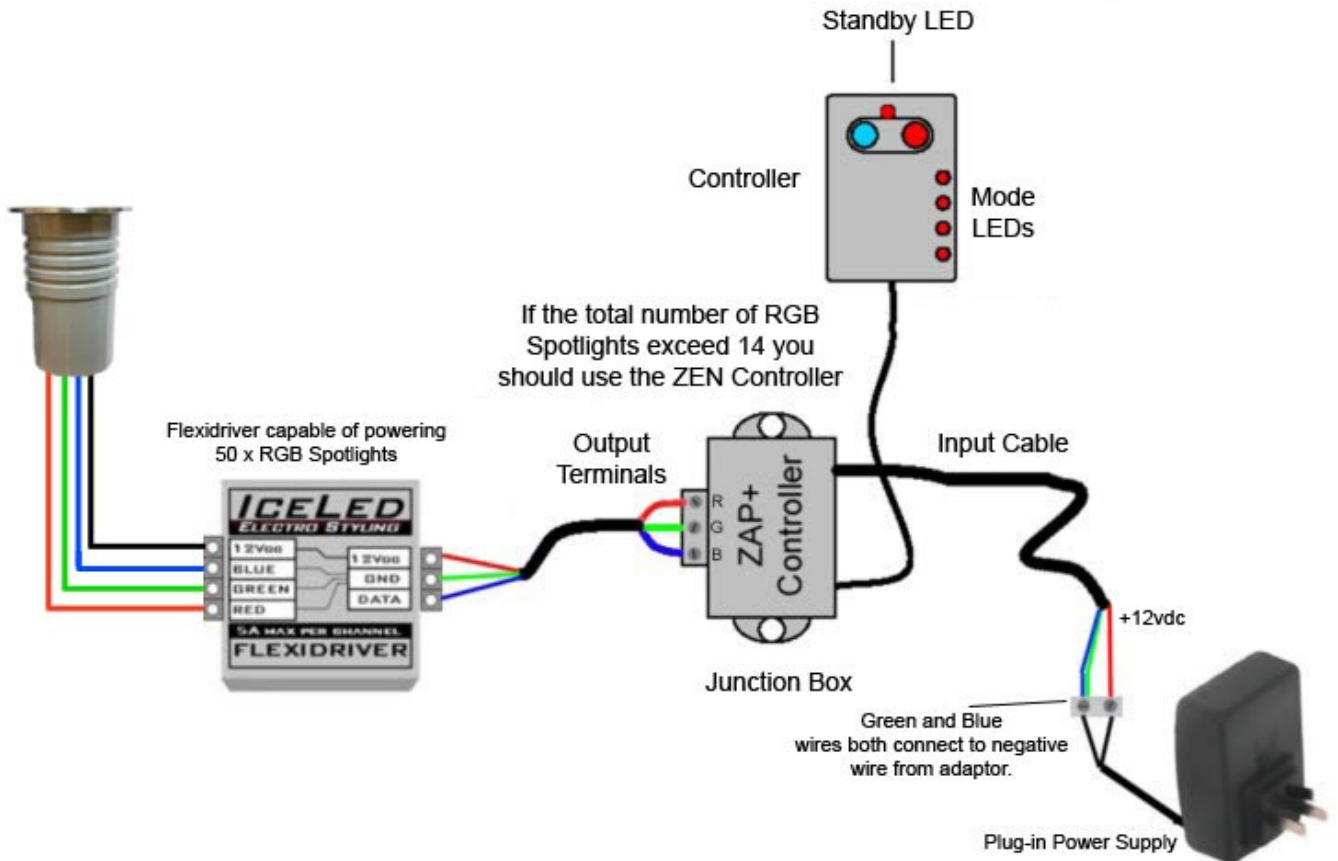

**NOTE:** The maximum number of RGB Spotlights that can be connected using this method are 14. If you wish to power more than that using the ZAP+ Controller please contact us and we will email you an alternative diagram.

To power the maximum amount 14 x Spotlights (for a ZAP+) a 3.5A Power Supply is required.

The plastic sleeve is supplied for fitting in-ground (concrete), or where the fixing surface is less than 15mm in thickness.

## Connection to a ZEN+ Controller:

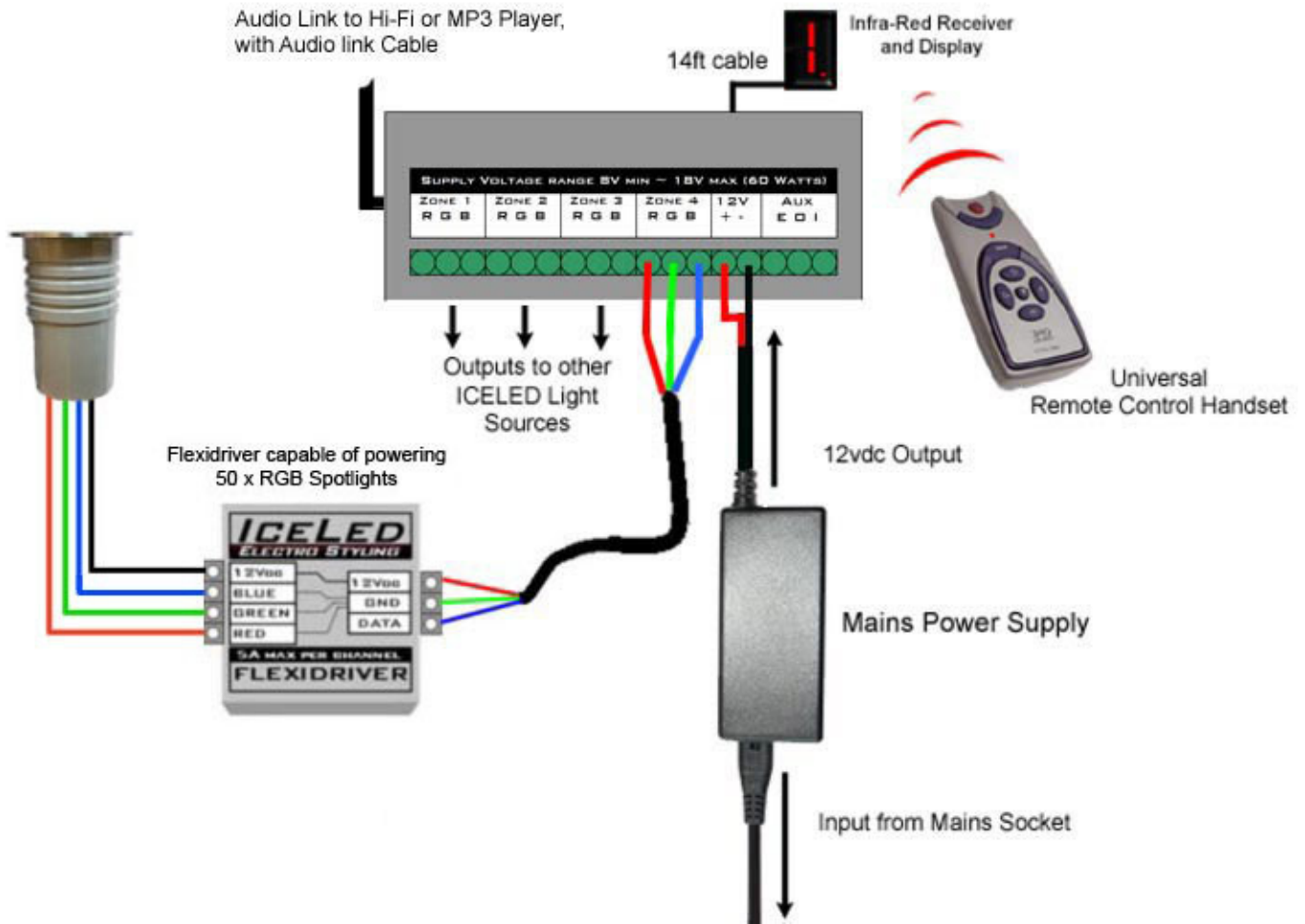

**NOTE:** The maximum number of RGB Spotlights connected to the Zen should be no more than 40 RGB Spotlights.

To power the maximum amount of 40 x Spotlights via the ZEN Controller a 10A Power Supply is required.

The RGB Spotlights should be wired in parallel. Connect all wires together into an appropriately rated junction or terminal block and run a 4-core cable rated for the total load to the output of the Flexidriver.

If a power supply having a significantly greater current capacity than the current requirement of the LED product(s) is to be used then a safety fuse will be required along the positive input wire to the Flexidriver, or Controller if used. This is to prevent excess current flowing through the supply wiring and LED product(s) under fault conditions such as accidental damage. Such a fuse must be located as near to the supply or driver to protect the installation wiring and shall have a current rating just higher than the total load anticipated under normal operating conditions.

**Note** that a fuse may only be omitted from the low voltage side if the power supply provides its own overload protection and is unable to significantly exceed the maximum rating of the wiring and LED product before it trips.

If linking the Flexidriver to a ZAP+ or ZEN Controller, the cable or wire should be rated according to the total load.

If a power supply having a significantly greater current capacity than the current requirement of the LED product(s) is to be used then a safety fuse will be required along the positive input wire to the product. This is to prevent excess current flowing through the supply wiring and LED product(s) under fault conditions such as accidental damage. Such a fuse must be located as near to the supply or driver to protect the installation wiring and shall have a current rating just higher than the total load anticipated under normal operating conditions.

**Note** that a fuse may only be omitted from the low voltage side if the power supply provides its own overload protection and is unable to significantly exceed the maximum rating of the wiring and LED product before it trips."

**If hard-wiring the input of the Power Supply to the AC mains it is essential to use a fused wall switch or outlet. The fuse on the mains side should be 3A or less. Only a qualified electrician should hard-wire the Mains PSU.**

**Power Supplies and Controllers are not waterproof and should be installed in a dry location.**

## Warranty

This product is warranted from manufacturing defect only. This warranty is valid for 1 year from the date of purchase. This warranty does not apply to damage caused by user installation or normal wear and tear. Cutting the tape will automatically void your warranty, so do so carefully. If a segment becomes faulty only that part can be replaced under warranty once cut.

Litewave Ltd gives no warranty against damage to any surface due to removing or applying this product.

Please follow instructions and warnings carefully.

## Specifications

Nominal supply voltage: 12 Volts DC (1)  
Viewing Angle: 45 Degrees  
Maximum current drain: 0.250 Amps (250ma)  
LED Type: 3w Emitter  
IP Rating: IP67.



Switchmode Power Supply recommended.

## Fuse Sizes:

**(use nearest possible size fuse):**

1 x RGB Spotlight = 250ma  
6 x RGB Spotlights = 2A

2 x 1 x RGB Spotlights = 500ma  
8 x 1 x RGB Spotlights = 2A

3 x 1 x RGB Spotlights = 1 Amp  
10 x RGB Spotlights = 2.5A

## Resources

To see the full Litewave product range visit <http://www.litewave.co.uk>

## Environmental Information



At the end of this product's usable life it should be disposed of according to WEEE regulations, which means it should be taken to your local municipal site for safe disposal/recycling.

## Safety Information:

- Keep away from children

- The product itself and all its components should not be mechanically stressed.
- Installation must not damage or destroy conducting paths or other parts of the product
- Installation of LED product (with power supplies) needs to be made with regard to all applicable electrical and safety standards. Only qualified personnel should be allowed to perform installations.
- Correct electrical polarity needs to be observed. Wrong polarity may damage or destroy the LED product.
- Parallel connection is highly recommended as safe electrical operation mode.
- Serial connection is not recommended. Unbalanced voltage drop can cause hazardous overload and damage the strip.
- Please ensure that the power supply is of sufficient power to operate the total load.
- Only power the LED product with Switchmode Power Supplies (constant voltage). Do not use a constant current Power Supply.
- If fixing on metallic or otherwise conductive surfaces, there should be an electrical insulator between the product and the mounting surface.
- All LEDs are static sensitive.
- Damaged by corrosion will not be honored as a materials defect claim. It is the user's responsibility to provide suitable protection against corrosive agents such as moisture and condensation and other harmful elements.
- Identify Positive (+) and negative (-) outputs of the Power Supply by using a multimeter.
- Electrical Connections should be in a dry area unless adequately sealed.

LITEWAVE LTD. MAKES NO WARRANTY, EITHER EXPRESSED OR IMPLIED, INCLUDING BUT NOT LIMITED TO ANY IMPLIED WARRANTIES OF MERCHANTABILITY OR FITNESS FOR A PARTICULAR PURPOSE, REGARDING THESE LITEWAVE LTD. MAKES PRODUCTS AVAILABLE SOLELY ON AN "AS-IS" BASIS. IN NO EVENT SHALL LITEWAVE LTD. BE LIABLE TO ANYONE FOR SPECIAL, COLLATERAL, INCIDENTAL, OR CONSEQUENTIAL DAMAGES IN CONNECTION WITH OR ARISING OUT OF PURCHASE OR USE OF LITEWAVE PRODUCTS. THE SOLE AND EXCLUSIVE LIABILITY TO LITEWAVE LTD, REGARDLESS OF THE FORM OF ACTION, SHALL NOT EXCEED THE PURCHASE PRICE OF THE LITEWAVE PRODUCT DESCRIBED HERE IN.