



WARNING

This product has been deliberately designed to create a highly noticeable lighting effect that will turn heads at car shows and exhibitions. Because of this it is EXTREMELY important that it is **not used on the public highway** to prevent the distraction of other road users.

Having issued this warning ICELED Ltd. Will not accept any responsibility for issues arising from any failure to comply with this clear instruction.

ICELED Ltd. Will not accept responsibility for any other issues arising from improper use or fitting of this product as these matters are beyond our control.

This product uses CLASS 2 LED devices (with respect to IEC825-1 & CENELEC EN 60825-1) While not considered to be hazardous, direct viewing of the LED's at close range should be avoided.

This product is capable of producing stroboscopic lighting effects when connected to external controllers.

Features

ICELED FLOOD is a powerful digital light source capable of emitting an intense 100 degree “floodlight” beam in any of over two million different colours. It has been designed to complement and integrate with other devices in the ICELED range of networked lighting products and can connect directly to controllers like UFO and ZEN. It will also function in a useful stand-alone mode allowing it to be used with nothing more than a 12 Volt supply. This makes ICELED FLOOD a direct replacement for neon in many interior and exterior applications – with the added advantage of being able to produce almost any colour in the visible spectrum. FLOOD is available in two formats – “Interior” or “Exterior”.

Interior FLOOD is a compact unit with an integral lead and optional internal through-cable facility for linking-in additional units.



Exterior FLOOD performs identically to the interior version but is encapsulated in a robust waterproof housing making it particularly suitable for use in harsh outdoor environments.



Wheel lighting kit

A Special wheel lighting kit consisting of four exterior FLOODs is supplied with two units pre-configured to show the colour of the rear-most pixel of the UFO side channel (for lighting the rear wheels) and two units pre-configured to show the colour of the front-most pixel (for lighting the front wheels). It is important to install each device in its appropriate location. A label on the underside of each light source identifies it as being part of the front or rear pair.

Interior FLOOD installation

The case can be attached in a number of ways. The base of the unit can be removed to expose a pair of outlines for ‘key hole’ slots. The base itself can be fixed directly to a surface using screws or adhesive pads if the surface cannot be drilled. The lid is a press-fit back on the base – taking care to align the four internal guide posts.

Exterior FLOOD installation

The case has a pair of mounting lugs ready to take two self-tapping screws or bolts. Exterior FLOOD is shock resistant and waterproof so can be mounted virtually anywhere. However keep both the unit and cable away from sources of excessive heat e.g. radiators or exhaust systems. Care should also be taken when routing the cable to prevent it snagging on any moving parts.

Wiring

A standard three-core cable connects both versions of the device to a power supply and data source.

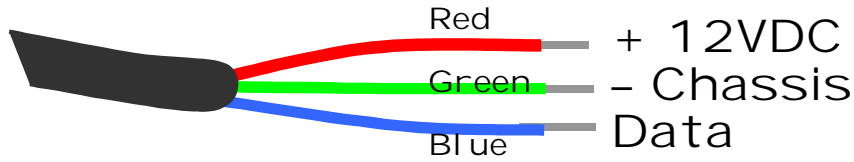

If the light source is to be connected to an ICELED controller supplying both power and data, then the colour coded wires simply connect to the corresponding terminals labelled R, G and B on the chosen output channel.

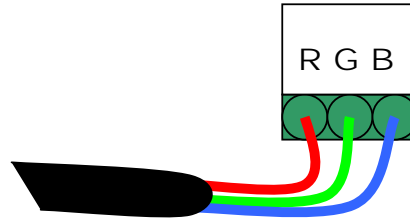

NOTE: It is perfectly acceptable to make multiple connections to the same terminal by twisting identically coloured wires together before inserting them into the terminal clamp.

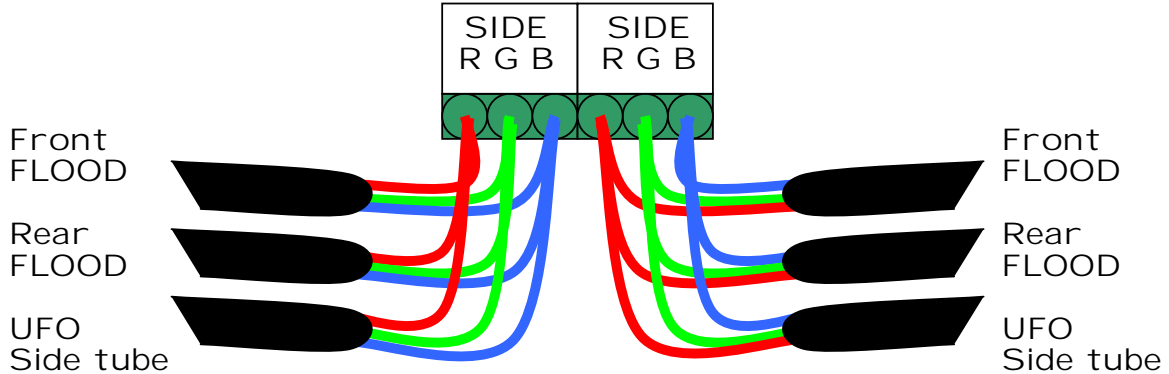

This will be necessary when adding the special wheel lighting kit to UFO in which case both front and both rear units on each side will be connected to the side channels on UFO. This requires three wires in each terminal as shown above.

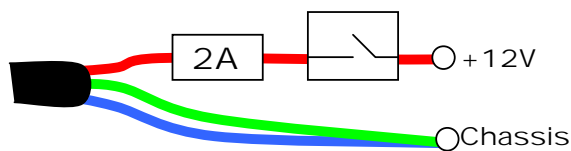

If the light source is to be used in stand-alone mode then the red wire must be connected via a 2Amp fuse to a nominal 12 VDC supply via a switch. The green and blue wires should be joined together and connected to chassis.

Linking-in other light sources

It is also possible to 'daisy chain' additional light sources to interior FLOOD by making connections to an internal three-way terminal block. By doing this the wiring to additional devices can be made without running more cables back to the controller. The base of the unit can be prised off to reveal the three terminals as shown below:

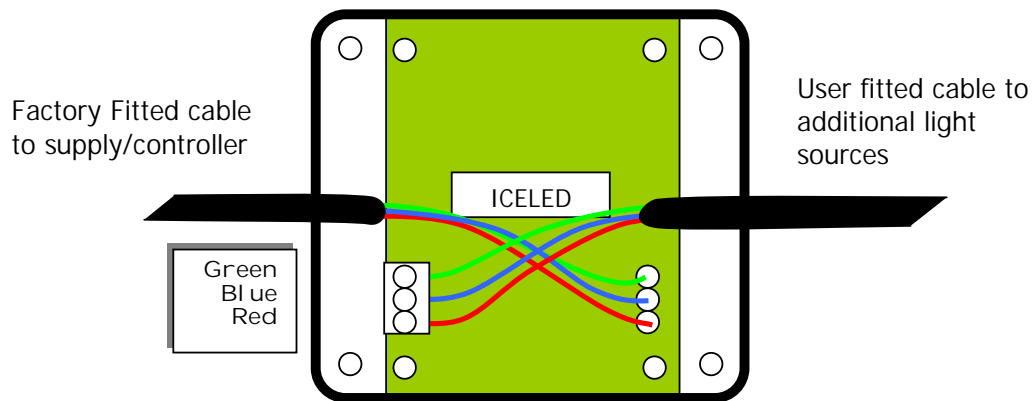

The coloured wires should be connected to the corresponding terminals shown on the left taking care not to let any loose strands 'creep' out of the connector and cause 'shorts' on the circuit board.

Any type of ICELED light source may be connected to these terminals so long as the total loading is kept below the fuse rating supplying the chain. This is specified as the maximum "through" current in the Specification data and represents a safe loading on the supply cable and circuit board. In practical terms this would allow for a maximum of 5 FLOODS in a chain. Other devices may draw more or less current so the total load should be checked first - by adding the maximum current figures given for each device from their specifications and making sure the total does not exceed 2 Amps.

Operation

If ICELED data is present when FLOOD is powered it will produce the colours commanded by the controller. If no data is present when the power is applied, FLOOD will start running an internal programme designed to provide as much functionality as possible with only the interruption of the supply voltage as a control system.

The built-in programme runs through the four phases labelled A to D in the following diagrams:

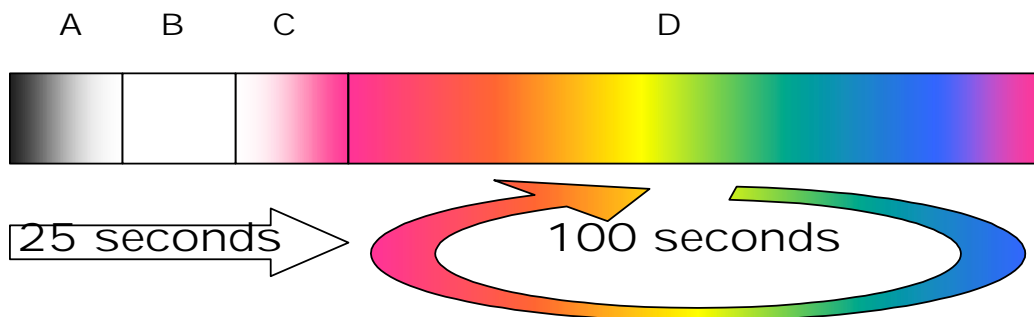

Phase Description

- A Rapid fade-up to peak intensity white after connection to the power source
- B Hold on peak white
- C Gentle transition from peak white to the colour change phase
- D Colour phasing - cycles seamlessly through the visible spectrum until power disconnected

Freezing the colour At any time, the programme may be halted by briefly switching the power supply off then back on (within less than a second). This simple action allows the light source to be frozen on any particular colour (or white) just by toggling the switch controlling power to the device. A single flash from the LED's provides acknowledgment that this command has been accepted.

Un-freezing The light source will remain frozen on the chosen colour until the next time it is switched off. Once again, if the supply is interrupted for less than a second, the programme will resume from where it left off (acknowledged by two flashes) If switched off for any longer, the programme will resume from the start the next time it is powered up.

Specifications

Unless stated, all figures apply to both types of FLOOD.

Nominal supply voltage:	12 Volts DC ⁽¹⁾
Maximum current drain:	0.35 Amps
Typical current drain:	0.15 Amps
Maximum "through" current:	2.0 Amps
Beam angle:	100 degrees
Data accepted:	Global ICELED UFO tube segment 0, pixel 0 UFO tube segment 3, pixel 2 ⁽²⁾
Dimension:	Interior FLOOD W 70mm H 70mm D 27mm Exterior FLOOD W 105mm H 72mm D 35mm

⁽¹⁾ On-board current regulation guarantees that the light source operates consistently at peak intensity over a wide supply Voltage range of between 8 and 18 Volts. Reverse polarity and over-voltage protection are also built in. Brief surges to 24 Volts can be tolerated.

⁽²⁾ For wheel lighting kit front pair only.

www.ICELED.co.uk

Resources

To see the full ICELED product range visit <http://www.iceled.co.uk> the official ICELED website.

For more suggestions and advice visit <http://iceled.co.uk/area51/> the official ICELED user forums.